

# 860-930MHz 5.8dBi LoRaWAN Antenna Black Datasheet

## Overview

---



Figure 1: Antenna Black Overview

## Features

- Frequency Range: **860–930 MHz**
- Max Gain: **5.9 dBi**
- VSWR:  $\leq 2$
- High Efficiency
- Vertically Polarized Dipole
- N-type connector
- Easy to mount with the included Installation kit

## Specifications

---

### Electrical Characteristics

Parameter	Value
Model	RAK 5.8 dBi
Frequency Range	860 MHz – 930 MHz
Peak Gain	5.9 dBi
VSWR	$\leq 2$
Efficiency	$\leq 83\%$
Feed Impedance	50 $\Omega$
Polarization	Vertical
Cover Material (color)	Fiberglass (black)
Connector Type	N-type male
Dimensions	800 mm ( $\pm 10$ ), $\Phi$ 25 mm
Operation Temperature	-30 °C + 65 °C
Storage Temperature	-30 °C + 75 °C
Humidity Range	5% ~ 95%

## VSWR

Frequency (MHz)	VSWR
860	1.83
930	1.45

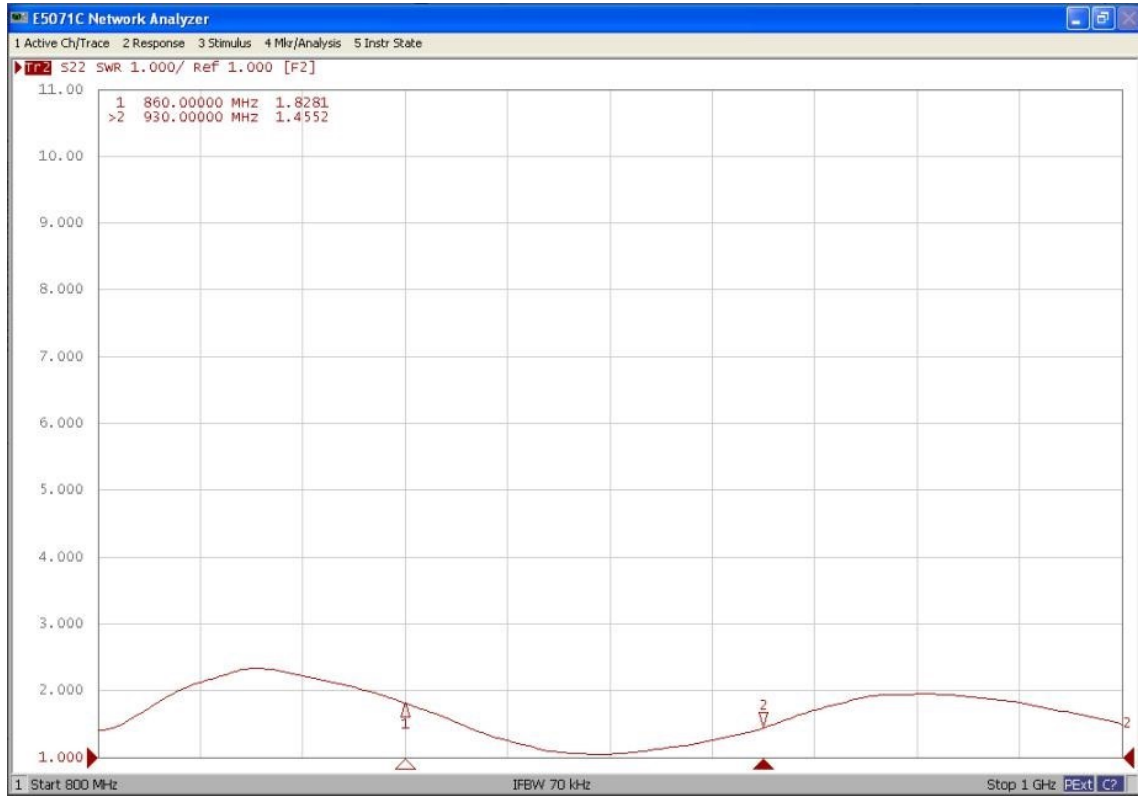

Figure 2: VSWR Graph

## Peak Gain & Efficiency

Frequency (MHz)	Gain (dBi)	Efficiency (%)
860	5.2	72%
865	5.2	73%
870	5.2	75%
875	5.3	78%
880	5.3	78%
885	5.3	78%
890	5.8	82%
895	5.8	83%
900	5.8	83%
905	5.9	83%
910	5.9	83%
915	5.8	83%
920	5.8	83%
925	5.9	83%
930	5.6	79%
Average		79.73%

## Radiation Patterns

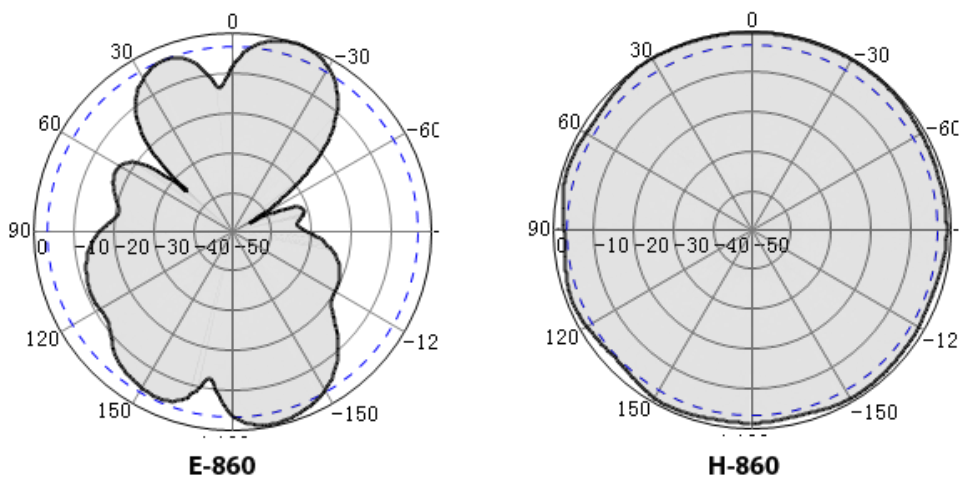

Figure 3: Radiation Pattern at 860MHz

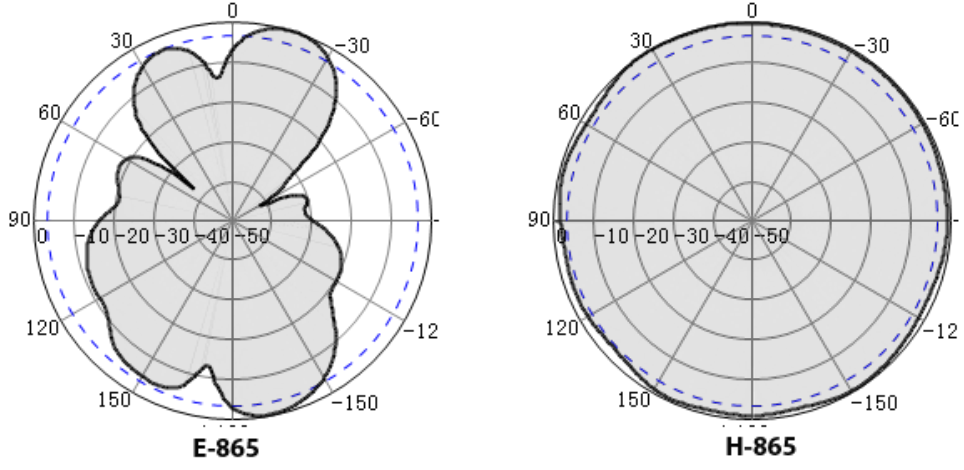

Figure 4: Radiation Pattern at 865MHz

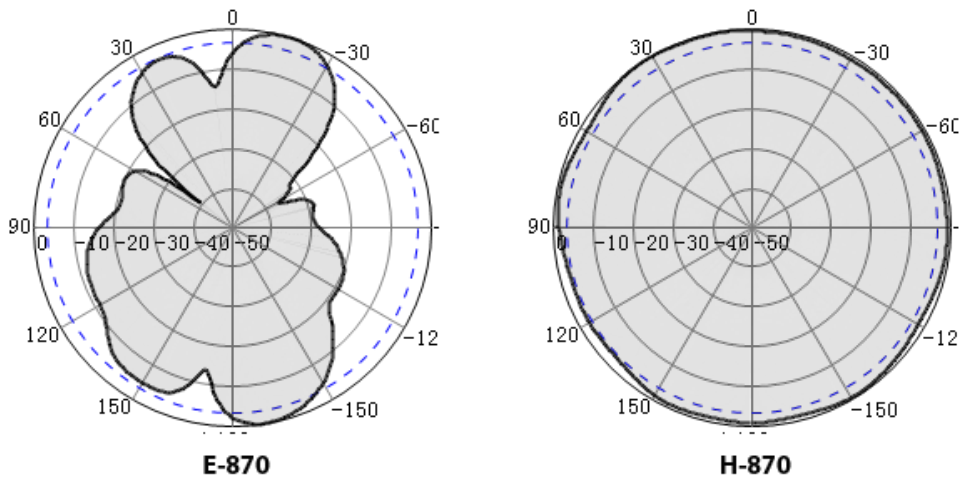

Figure 5: Radiation Pattern at 870MHz

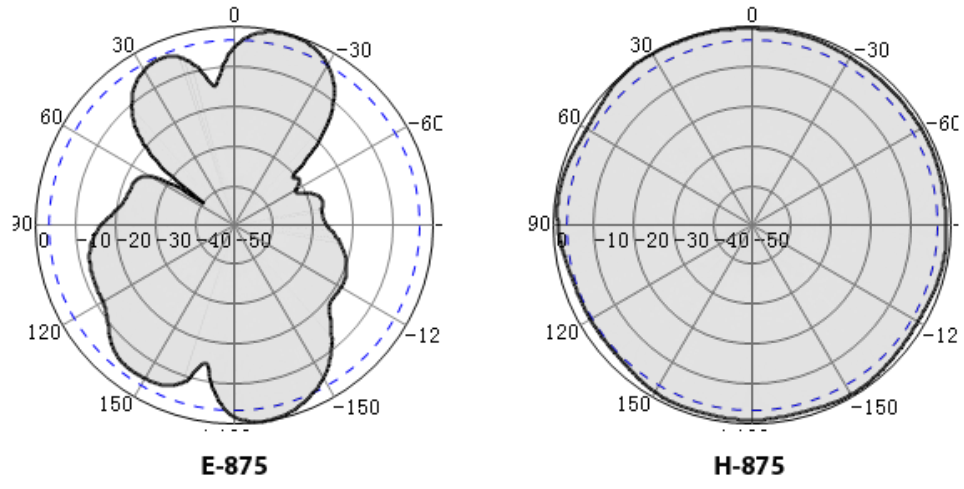

Figure 6: Radiation Pattern at 875MHz

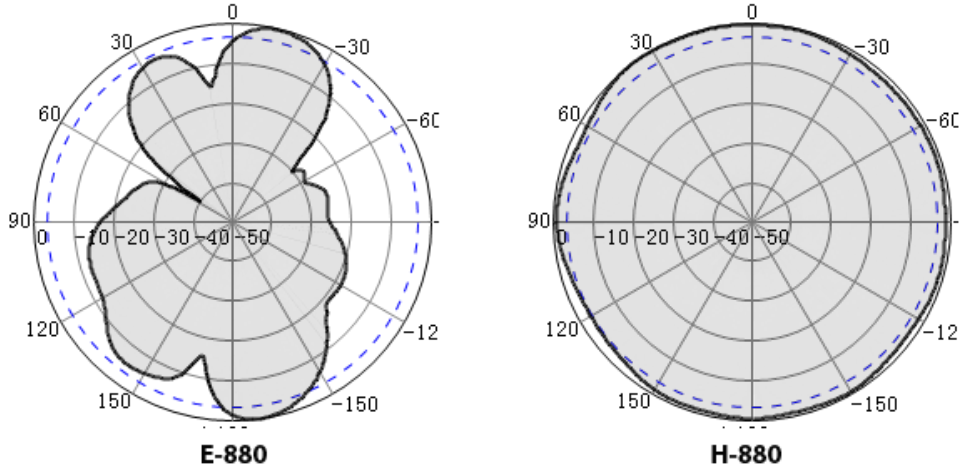

Figure 7: Radiation Pattern at 880MHz

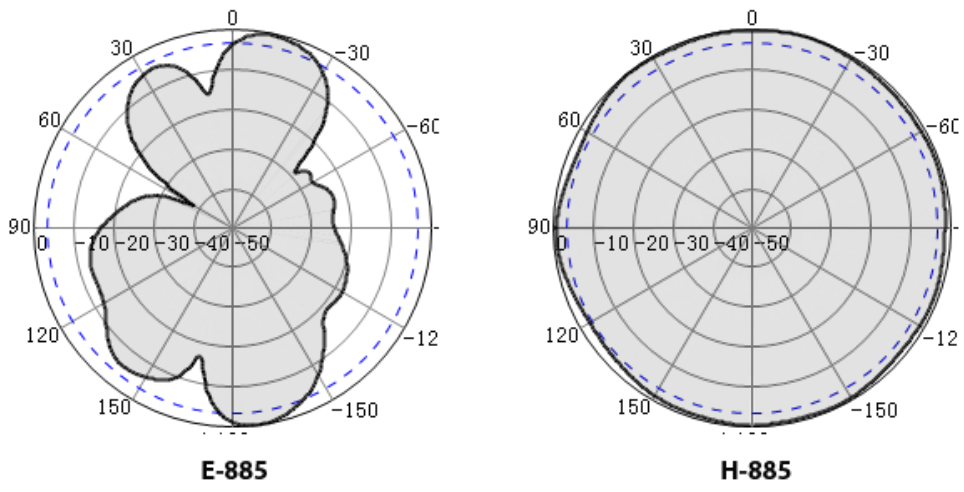

Figure 8: Radiation Pattern at 885MHz

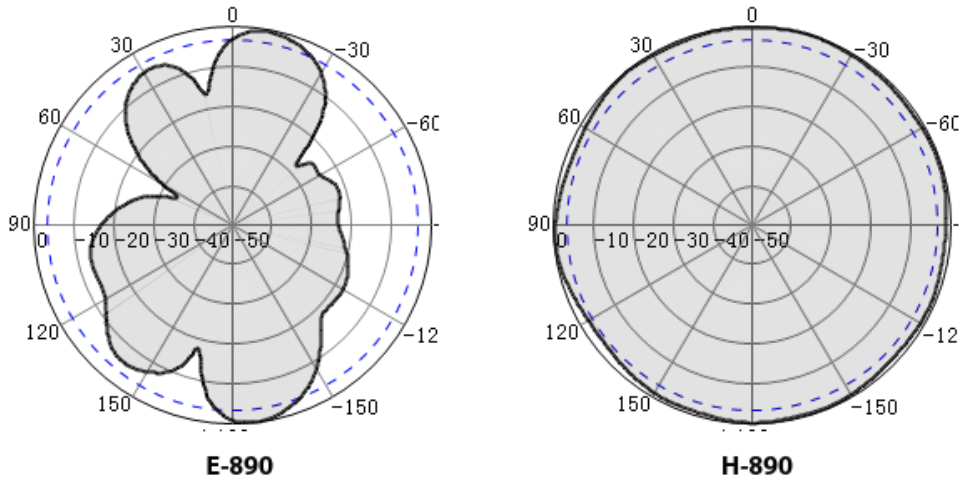
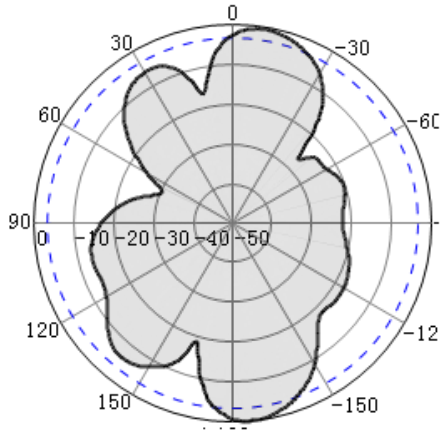
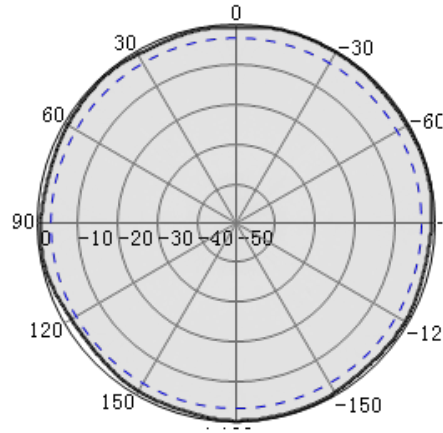

Figure 9: Radiation Pattern at 890MHz



**E-895**



**H-895**

Figure 10: Radiation Pattern at 895MHz

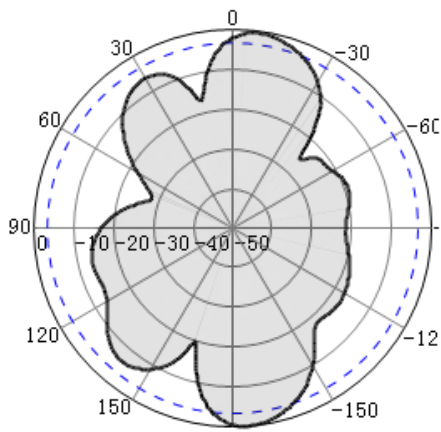

**E-900**

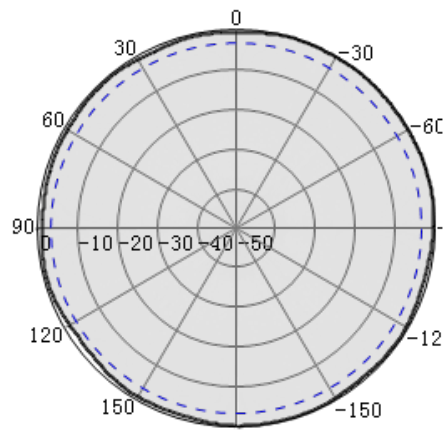

**H-900**

Figure 11: Radiation Pattern at 900MHz

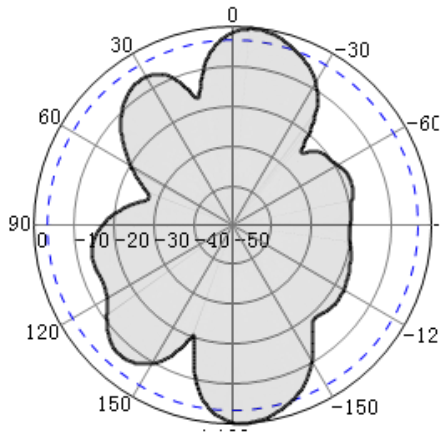

**E-905**

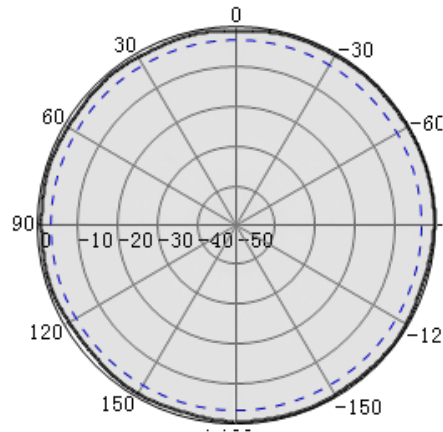

**H-905**

Figure 12: Radiation Pattern at 905MHz

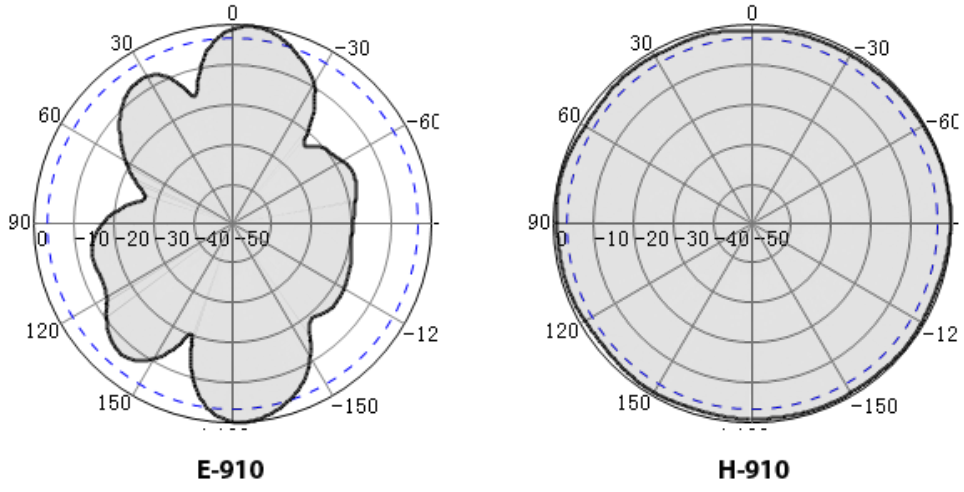

Figure 13: Radiation Pattern at 910MHz

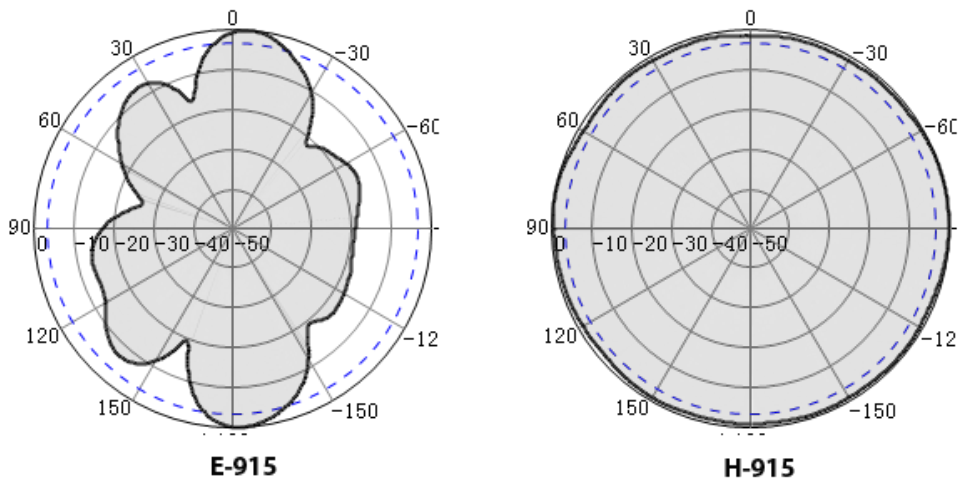

Figure 14: Radiation Pattern at 915MHz

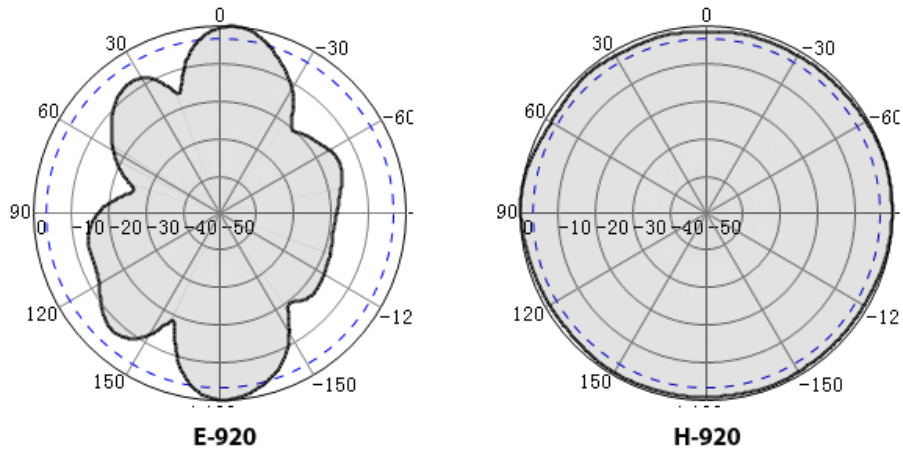

Figure 15: Radiation Pattern at 920MHz



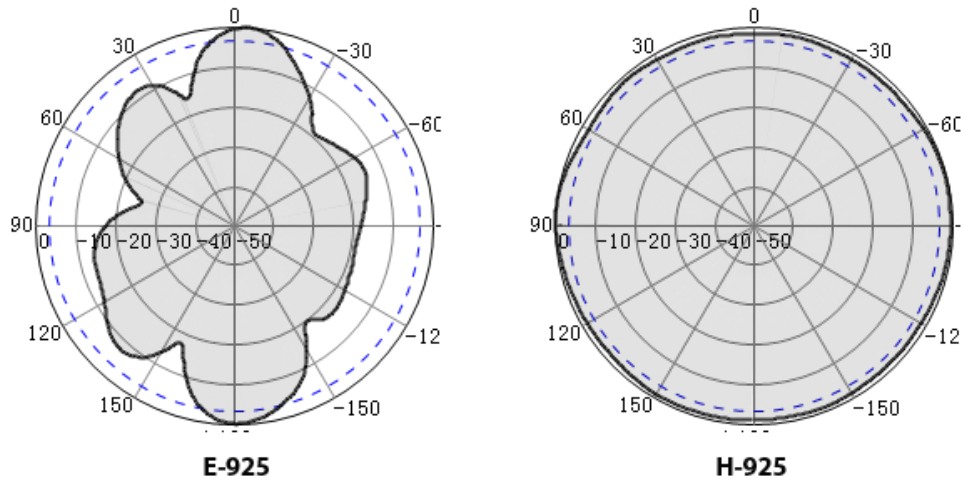

Figure 16: Radiation Pattern at 925MHz

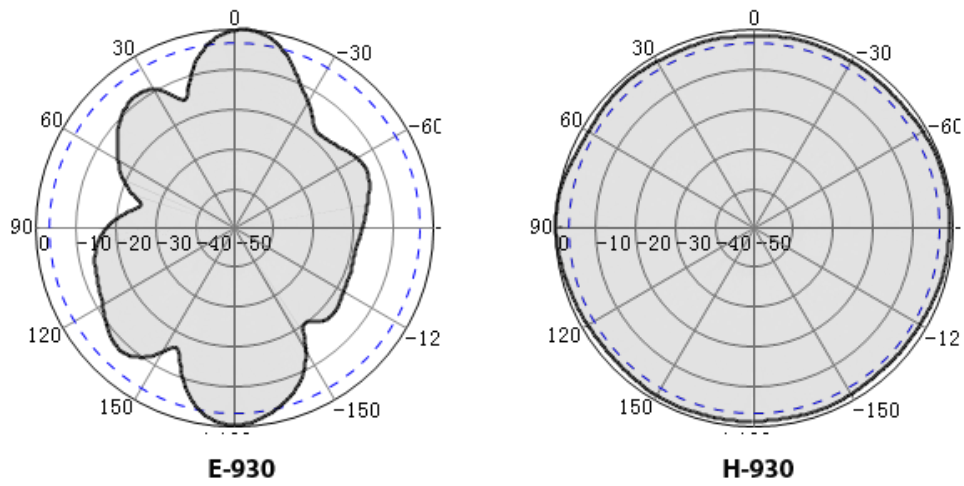

Figure 17: Radiation Pattern at 930MHz

## Mechanical Characteristics

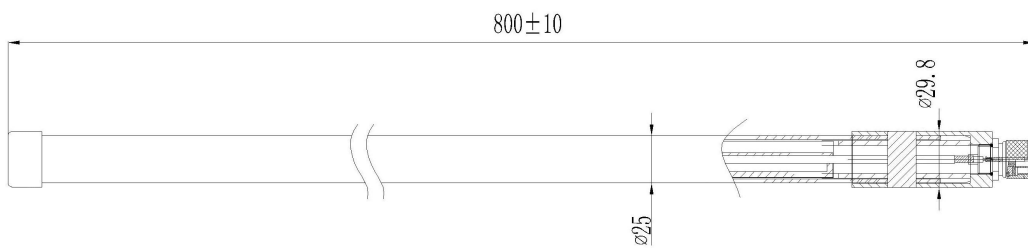

Figure 18: Mechanical Dimensions in mm